

## HTU-1000 Skid Mount

### Pressure Pump Specifications

- Type: Positive displacement, Triplex plunger pump
- Operating Volume: 140 gpm (530 Lpm)
- Operating Pressure: 2,193 psi (15,120 kPa)

### Fill Pump Specifications

- Type: Centrifugal Pump, Three stage
- Pump Output: 630 gpm (2,385 Lpm) at 1000 ft (305 m) of head pressure
- Operating Pressure: 435 psi (3,000 kPa)

### Power Source Specifications

- Type: Duetz diesel engine rated at 480 hp at 2100 rpm (358 kW at 2100 rpm)
- Capacity: 200 gallons diesel (755 liters)

### Skid Mount Specifications

- Transport Width: 96" (2,438 mm)
- Transport Length: 150" (3,810 mm)
- Transport Height: 84" (2,134 mm)
- Approx. Shipping Weight: 15,000 lbs. (6,805 kg)

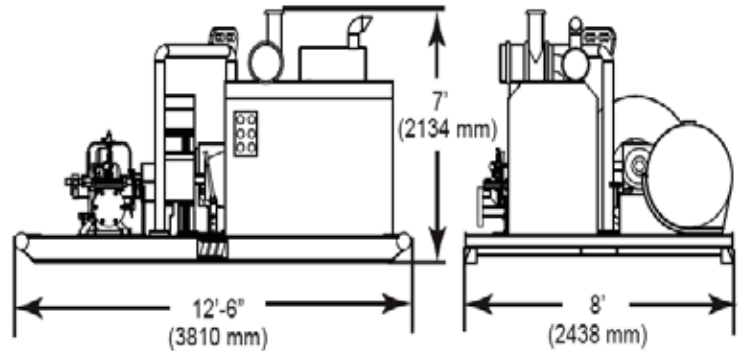

*'Includes suction strainer and 20 ft long suction hose with foot valve (not shown)*

## HTU-1000 Hydrostatic Fill and Test Unit